

# STEEL WORKTOPS

## INSPECT THE WORKTOP UPON DELIVERY!!!

If you have reason to submit a complaint regarding the delivered product, this must be reported to your retailer before installation begins and no later than 8 days after delivery.

Installation is considered acceptance of the product. Visible defects or faults that could have been identified prior to installation are therefore not covered by the warranty.

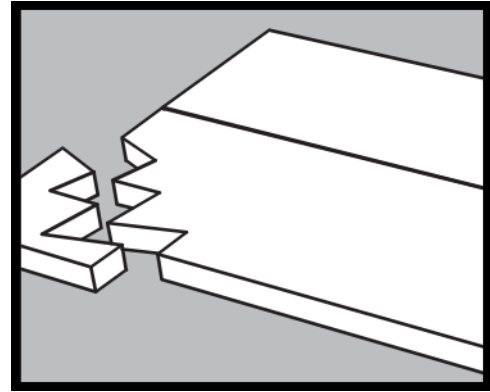

## TRANSPORT AND STORAGE

The worktop must always be lifted and carried in an upright position. It must never be carried horizontally. For storage, the worktop must be placed horizontally on a flat surface with the top surface facing downwards. The worktop must be allowed to acclimatise to room temperature before installation.

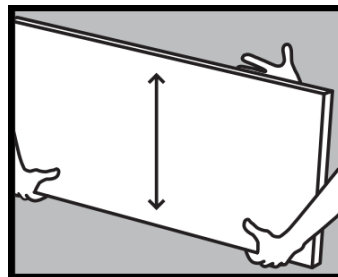

Cut-outs must not be used as "handles"

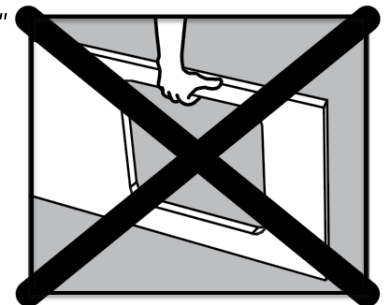

## GENERAL INFORMATION

To ensure that the worktop meets your expectations, it is important that it is transported, installed, and maintained correctly.

If these guidelines are followed, you will be able to enjoy your worktop for many years to come.

Stainless steel is a timeless material with an elegant, satin-matt finish.

It is hygienic, practical and highly durable, and resistant to most household liquids (except acids). Over time, the surface will develop scratches and acquire a natural patina, which is part of the material's character.

You may find it helpful to watch the laminate installation video when fitting a steel worktop with a chipboard core:

<https://www.dfi-geisler.com/en/montage-og-vedligeholdelse-af-laminat/>

For installation of flat steel, follow the guidance provided for composite: <https://www.dfi-geisler.com/en/montage-og-vedligeholdelse-af-kompositsten/>

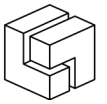

## BEFORE INSTALLATION

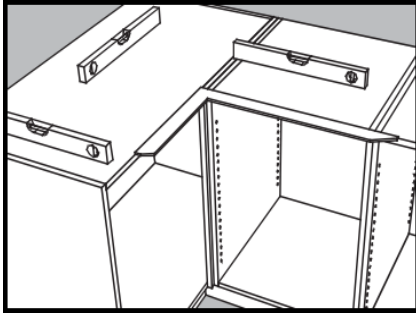

Please note that the instructions in this section cover both steel worktops with a chipboard core and flat steel worktops. Instructions that apply to only one type are clearly indicated in the text.

Before installation begins, use a spirit level to check that all cabinet units are level - longitudinally, laterally, and diagonally.

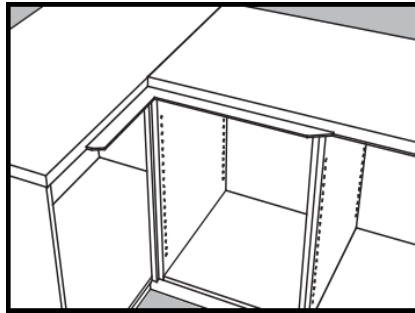

Place the worktop set loosely on the cabinet units to verify that all measurements, angles, and joints are correct. For worktops with a chipboard core, carry out a trial assembly using the fittings. Once checked, remove the worktops.

If any deviations are found, contact your retailer immediately. Note that all angles are manufactured square (90°) unless otherwise ordered.

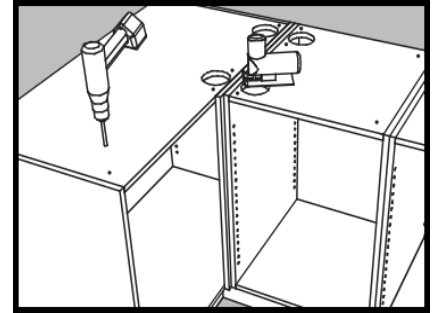

For cabinets with a fixed top, cut an opening in the top or in the cabinet sides to allow the joint fittings to be tightened from inside the cabinet (for worktops with a chipboard core). Pre-drill fastening holes in the cabinets as close to the front edge, back edge and all vertical cabinet sides as possible (for worktops with a chipboard core).

Fit metal support rails to the front of cabinets with cut-outs, e.g., for a hob, as well as in cabinets wider than 600 mm.

## INSTALLING STEEL WORKTOPS WITH A CHIPBOARD CORE

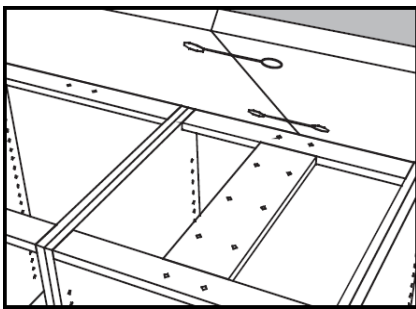

Place the worktops on the cabinets for final fastening. Pull the worktops slightly apart and apply sealant. Push the worktops back together. All joints must be fully supported and secured with paired screws. For cabinets without a top, the joint must be supported with a nail plate.

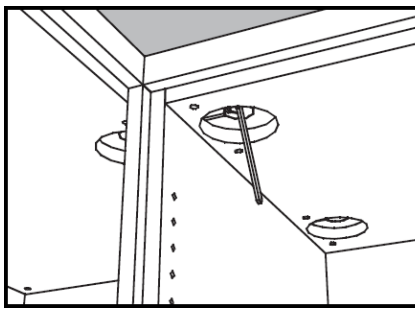

Fit the joint fittings and tighten them alternately, taking care not to overtighten them.

If there is a height difference in the joint, insert a packer to ensure the surfaces are level.

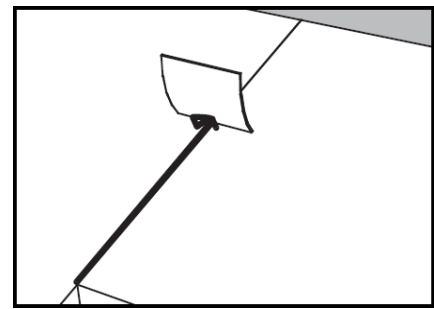

Remove any excess sealing material with a piece of cardboard, working from the back edge towards the front edge. Any remaining sealant can be removed with Surface Cleaner.

No warranty is provided for water ingress in the joints.

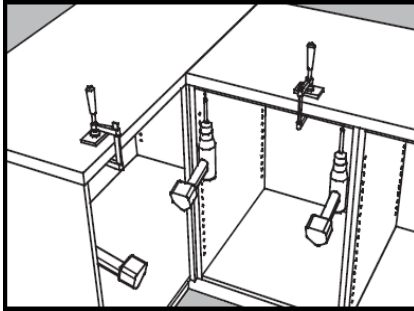
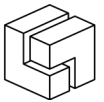

Fasten the worktops in the pre-drilled screw holes. The ends of the worktop must always be secured. If needed, the worktop can be held in place with clamps during installation - remember to protect the steel surface.

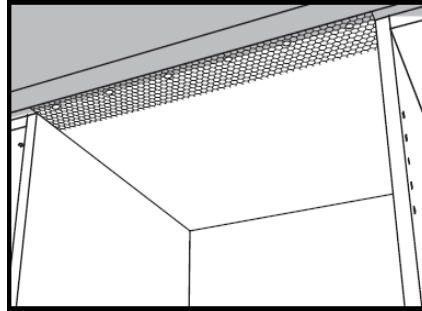

**Appliances:**

For heat- and moisture-emitting sources such as sinks, dishwashers, ovens, wine coolers and similar appliances, aluminium tape must be fitted along the front edge to prevent moisture ingress. The aluminium tape must be applied at least 20 cm before and 20 cm after the source - extending fully over the folded steel edge. The tape is then trimmed with a utility knife.

Aluminium tape must also be fitted around cut-outs, for example for a hob.

Free-standing cookers must always be raised 5 mm above the worktop level.

## INSTALLATION OF FLAT STEEL WORKTOPS

- Place the worktops on the cabinets for final installation.
- Pack under the worktops to ensure the joint is flush and the worktops are level.
- Pull the worktops slightly apart and apply sealing material in the joint before pushing the worktops back together.
- Remove any excess sealing material with a piece of cardboard, working from the back edge towards the front edge. Any remaining residue can be removed with Surface Cleaner.
- Secure the worktops from underneath using installation adhesive.
- Free-standing cookers must always be raised 5 mm above the worktop level.

How to maintain your.....

# STEEL WORKTOP

---

Stainless steel is an exceptionally durable and hygienic material. It requires minimal maintenance and, with normal day-to-day use, the surface will gradually develop a natural patina that is characteristic of the material.

## **IMPORTANT - BEFORE YOU START USING YOUR WORKTOP:**

Before delivery, your steel worktop has been treated with 3M Stainless Steel Cleaner to clean and protect the surface. Once the worktop is fully installed, wipe it with a soft cotton cloth wrung out in clean, warm water – optionally with a small amount of washing-up liquid added. If a cleaning agent is used, always rinse the surface afterwards with clean, warm water. Finish by wiping the worktop with a dry, lint-free cotton cloth to prevent limescale deposits.

Dried food residues are easily removed using warm water and a small amount of cleaning agent. Never scrape the steel surface, as this may cause scratches. Always rinse with clean, warm water and dry with a dry, lint-free cotton cloth.

Scratches will become part of the worktop's natural patina. Minor, isolated scratches may be reduced using a nylon sponge. Always work in the direction of the surface finish (brushed steel), where applicable.

NEVER use steel wool, steel sponges or similar abrasive products.

Steel tolerates ordinary household cleaning agents.

Strongly acidic products, such as descalers and beaching agents, must be removed immediately, as they may leave marks on the surface.

Steel does not tolerate temperatures above 95°. Always use trivets or similar heat protection.

### **Daily cleaning:**

Wipe the steel surface with a soft cotton cloth wrung out in clean, warm water – optionally with a small amount of washing-up liquid. If a cleaning agent is used, rinse with clean, warm water afterwards. Finish by wiping with a dry, lint-free cotton cloth to prevent limescale deposits.

Limescale deposits can be removed using ordinary household vinegar (5 - 7 %). Rinse thoroughly with clean, warm water and dry with a dry, lint-free cotton cloth.

Cleaning and care products are available from your retailer:

Steel care set: for both deep cleaning and daily maintenance.

Surface Cleaner: for surface cleaning.

Surface Cleaner instructions

- Ensure the surface is clean and moist.
- Clean only a small area at a time.
- Apply Surface Cleaner to the surface with a damp melamine sponge and clean with light circular movements.
- Leave for 5 minutes. Repeat cleaning if necessary.
- Ensure the product doesn't dry out at any time - neither during treatment nor during rinsing.
- Rinse with clean warm water repeatedly, until all Surface Cleaner has been removed.
- Wipe off with a dry lint-free cloth.

## **Maintenance of sinks:**

Our sink range includes more than 200 different models in a variety of materials, from leading suppliers.

All suppliers have their own cleaning and maintenance recommendations. If you want guidance from a specific supplier, we recommend visiting their website for exact instructions.

Here we have summarized the general recommendations for steel sinks:

### **Steel sinks - cleaning:**

To keep your steel sink clean, we recommend the following:

- Clean the sink daily, with a brush and washing-up detergent - rinse with clean water and wipe with a dry cloth. This will prevent limescale from building up in the sink.
- Beware of limescale as it can bind dirt and discoloration. Limescale can be removed with a mixture of household vinegar (5 - 7 %) and water (1:10) or a standard descaler (soak for 3 minutes) - always remember to rinse thoroughly and wipe with a dry cloth. Many sink suppliers offer their own cleaning and care products - check their websites for recommendations.
- Pay extra attention to limescale build-up if you have a 'boil' tap, as limescale is more likely to precipitate and settle on the surface as the water heats up. To avoid this, wipe down the sink daily and descale it regularly.
- Avoid constant exposure to boiling water in the same place on the surface of the sink, as limescale will build up in that area. If the boiling tap is used for scalding or cleaning, it is recommended to place a pot or similar in the bottom of the sink.
- Remove persistent grease or dirt with a soft sponge and a common cleaning agent. Always remember to clean in the grinding direction of the steel and rinse thoroughly after cleaning.

### **Steel sinks – care:**

- From time to time, a stainless-steel polish may be required to restore the sink to its original appearance. Look for polishes on sink suppliers' websites.

### **Avoid the following:**

- Abrasives: Never use scouring powder, steel wool, steel sponges or other abrasive cleaners.
- Detergents containing chlorine.

Rinse and wipe immediately if contact with acidic foods such as juice, tea, mustard, alcohol or mayonnaise.

If rust stains appear, it's not the sink itself that's corroding. It's usually caused by rust particles from other objects such as tins, kitchen utensils and cookware. Use a damp cloth and a common detergent to remove them.